





<p>Description</p> <p>The Power MOSFET is fabricated using the advanced planer VDMOS technology. The resulting device has low conduction resistance, superior switching performance and high avalanche energy.</p> <p>Features</p> <ul style="list-style-type: none"> ◆ Low $R_{DS(on)}$ ◆ Low gate charge (typ. $Q_g = 40.8$ nC) ◆ 100% UIS tested ◆ RoHS compliant <p>Applications</p> <ul style="list-style-type: none"> ◆ Power factor correction. ◆ Switched mode power supplies. ◆ LED driver. 	<p>Product Summary</p> <table> <tr> <td>V_{DSS}</td> <td>600V</td> </tr> <tr> <td>I_D</td> <td>12A</td> </tr> <tr> <td>$R_{DS(on),max}$</td> <td>0.75Ω</td> </tr> <tr> <td>$Q_{g,typ}$</td> <td>40.8 nC</td> </tr> </table> <div style="display: flex; justify-content: space-around; align-items: center;"> <div style="text-align: center;">  <p>TO-262</p> </div> <div style="text-align: center;">  <p>TO-263</p> </div> <div style="text-align: center;">  <p>TO-220</p> </div> <div style="text-align: center;">  <p>TO-220F</p> </div> </div> <div style="text-align: center; margin-top: 20px;">  <p>N-Channel MOSFET</p> </div> <div style="text-align: right; margin-top: 10px;">  </div>	V_{DSS}	600V	I_D	12A	$R_{DS(on),max}$	0.75 Ω	$Q_{g,typ}$	40.8 nC
V_{DSS}	600V								
I_D	12A								
$R_{DS(on),max}$	0.75 Ω								
$Q_{g,typ}$	40.8 nC								

Absolute Maximum Ratings

Parameter	Symbol	Value	Unit
Drain-Source Voltage	V_{DSS}	600	V
Continuous drain current ($T_C = 25^\circ\text{C}$)	I_D	12	A
($T_C = 100^\circ\text{C}$)		7.5	A
Pulsed drain current ¹⁾	I_{DM}	48	A
Gate-Source voltage	V_{GSS}	± 30	V
Avalanche energy, single pulse ²⁾	E_{AS}	605	mJ
Peak diode recovery dv/dt ³⁾	dv/dt	5	V/ns
Power Dissipation TO-220F ($T_C = 25^\circ\text{C}$)	P_D	42	W
Derate above 25°C		0.34	W/°C
Power Dissipation TO-220\ TO-262\ TO-263 ($T_C = 25^\circ\text{C}$)	P_D	150	W
Derate above 25°C		1.2	W/°C
Operating junction and storage temperature range	T_J, T_{STG}	-55 to +150	°C
Continuous diode forward current	I_S	12	A
Diode pulse current	$I_{S,pulse}$	48	A

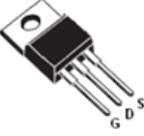
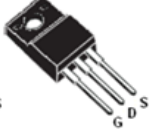
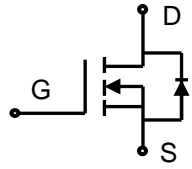
Thermal Characteristics

Parameter	Symbol	Value		Unit
		TO-220F	TO-220\TO-251\TO-252	
Thermal resistance, Junction-to-case	$R_{\theta JC}$	2.98	0.83	°C/W
Thermal resistance, Junction-to-ambient	$R_{\theta JA}$	110	62.5	°C/W

Electrical Characteristics T_c = 25°C unless otherwise noted

Parameter	Symbol	Test Condition	Min.	Typ.	Max.	Unit
Static characteristics						
Drain-source breakdown voltage	BV_{DSS}	$V_{GS}=0\text{ V}, I_D=0.25\text{ mA}$	600	-	-	V
Gate threshold voltage	$V_{GS(th)}$	$V_{DS}=V_{GS}, I_D=0.25\text{ mA}$	2	-	4	V
Drain cut-off current	I_{DSS}	$V_{DS}=600\text{ V}, V_{GS}=0\text{ V},$ $T_j = 25^\circ\text{C}$ $T_j = 125^\circ\text{C}$	-	-	1 100	μA
Gate leakage current, Forward	I_{GSSF}	$V_{GS}=30\text{ V}, V_{DS}=0\text{ V}$	-	-	100	nA
Gate leakage current, Reverse	I_{GSSR}	$V_{GS}=-30\text{ V}, V_{DS}=0\text{ V}$	-	-	-100	nA
Drain-source on-state resistance	$R_{DS(on)}$	$V_{GS}=10\text{ V}, I_D=6\text{ A}$	-	0.53	0.75	Ω
Dynamic characteristics						
Input capacitance	C_{iss}	$V_{DS} = 25\text{ V}, V_{GS} = 0\text{ V},$ $f = 1\text{ MHz}$	-	1960	-	pF
Output capacitance	C_{oss}		-	163	-	
Reverse transfer capacitance	C_{rss}		-	7.2	-	
Turn-on delay time	$t_{d(on)}$	$V_{DD} = 300\text{ V}, I_D = 12\text{ A}$ $R_G = 10\ \Omega, V_{GS}=15\text{ V}$	-	14.3	-	ns
Rise time	t_r		-	37.6	-	
Turn-off delay time	$t_{d(off)}$		-	65.4	-	
Fall time	t_f		-	14.2	-	
Gate charge characteristics						
Gate to source charge	Q_{gs}	$V_{DD}=480\text{ V}, I_D=12\text{ A},$ $V_{GS}=0\text{ to }10\text{ V}$	-	11.0	-	nC
Gate to drain charge	Q_{gd}		-	15.6	-	
Gate charge total	Q_g		-	40.8	-	
Gate plateau voltage	$V_{plateau}$		-	5	-	V
Reverse diode characteristics						
Diode forward voltage	V_{SD}	$V_{GS}=0\text{ V}, I_F=12\text{ A}$	-	-	1.5	V
Reverse recovery time	t_{rr}	$V_R=300\text{ V}, I_F=12\text{ A},$ $di_F/dt=100\text{ A}/\mu\text{s}$	-	387.2	-	ns
Reverse recovery charge	Q_{rr}		-	3.87	-	μC
Peak reverse recovery current	I_{rrm}		-	20.3	-	A

Notes:

- Pulse width limited by maximum junction temperature.
- $L=10\text{mH}, I_{AS} = 11\text{A}$, Starting $T_j = 25^\circ\text{C}$.
- $I_{SD} = 12\text{A}, di/dt \leq 100\text{A}/\mu\text{s}, V_{DD} \leq BV_{DS}$, Starting $T_j = 25^\circ\text{C}$.

Electrical Characteristics Diagrams

Figure 1. Typical Output Characteristics

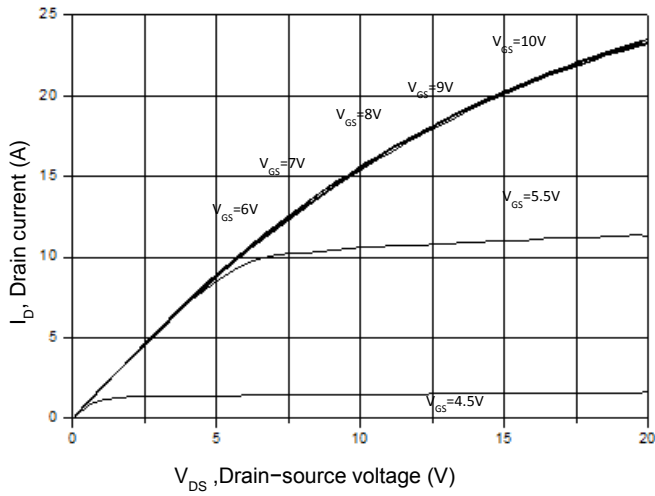

Figure 2. Transfer Characteristics

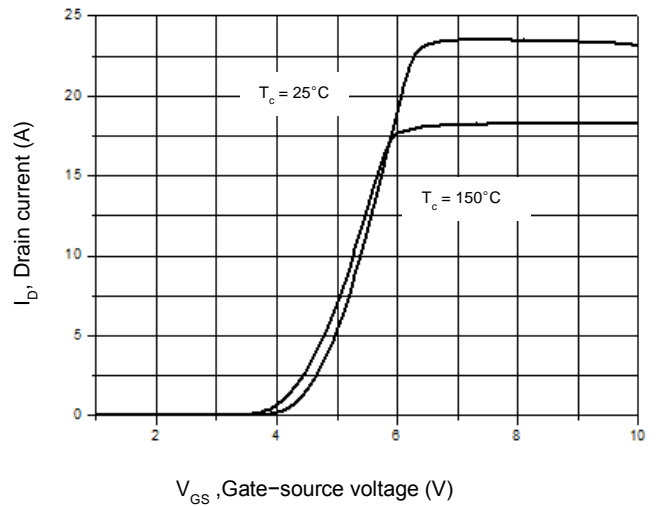

Figure 3. On-Resistance Variation vs. Drain Current

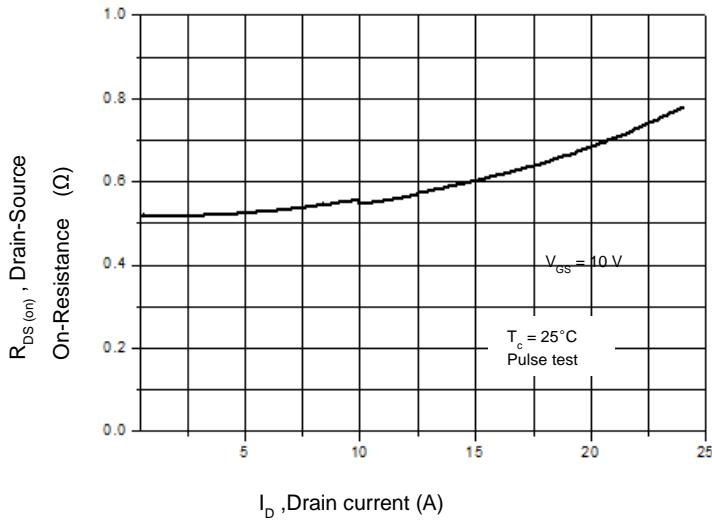

Figure 4. Threshold Voltage vs. Temperature

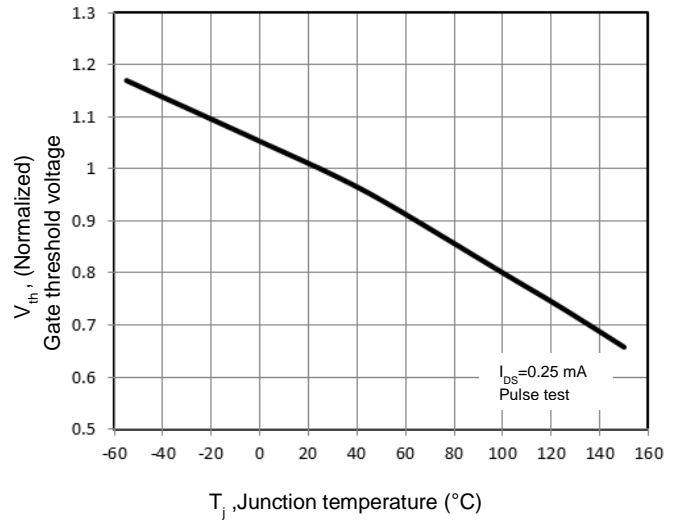

Figure 5. Breakdown Voltage vs. Temperature

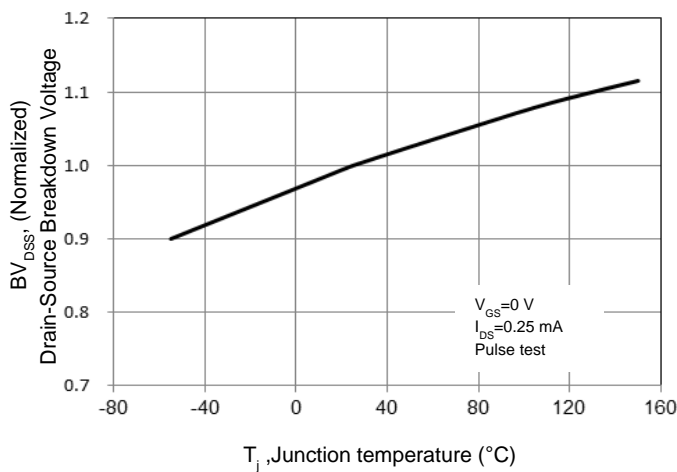

Figure 6. On-Resistance vs. Temperature

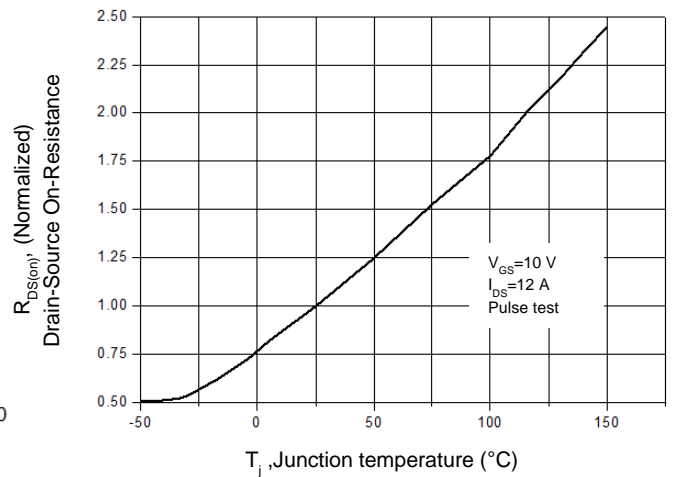

Figure 7. Capacitance Characteristics

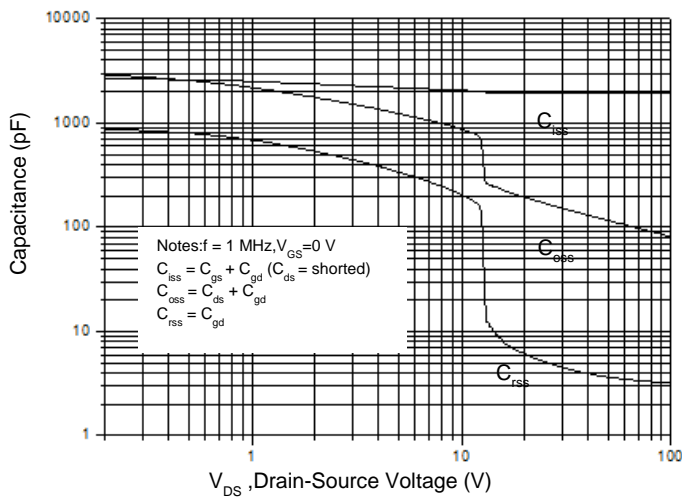

Figure 8. Gate Charge Characteristic

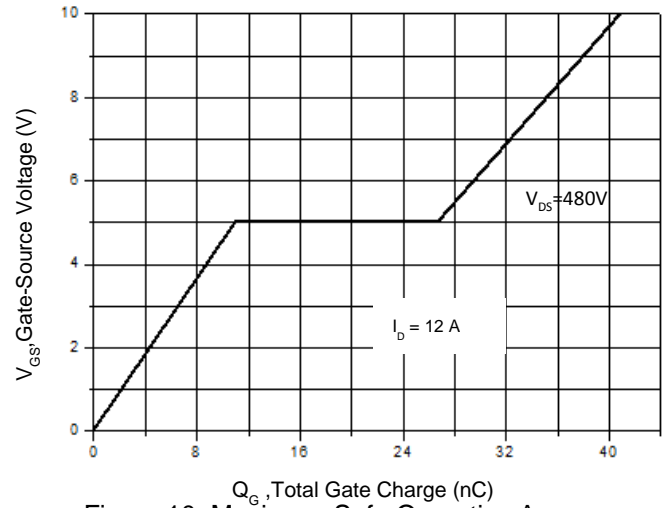

Figure 9. Maximum Safe Operating Area
TO-220F

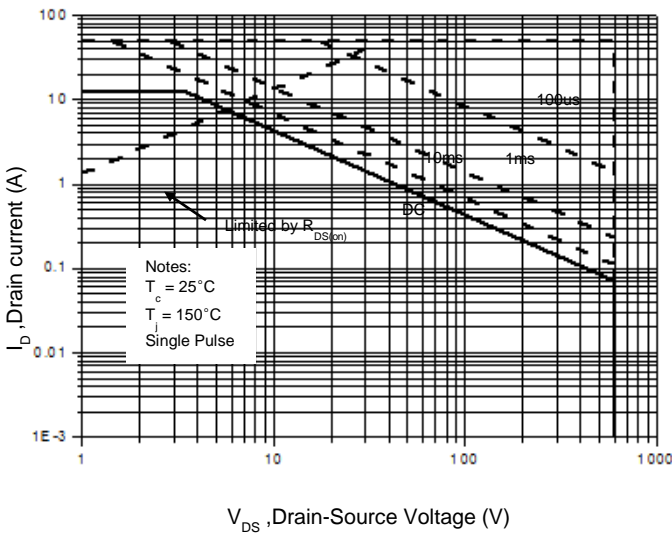

Figure 10. Maximum Safe Operating Area
TO-220/ TO-262/TO-263

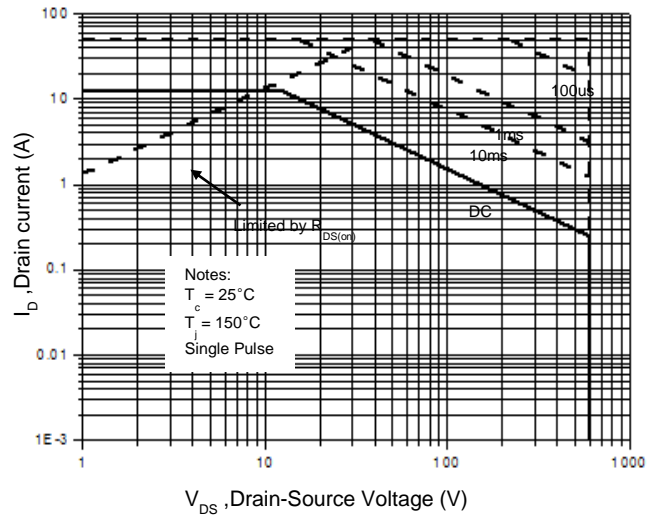

Figure 11. Power Dissipation vs. Temperature
TO-220F

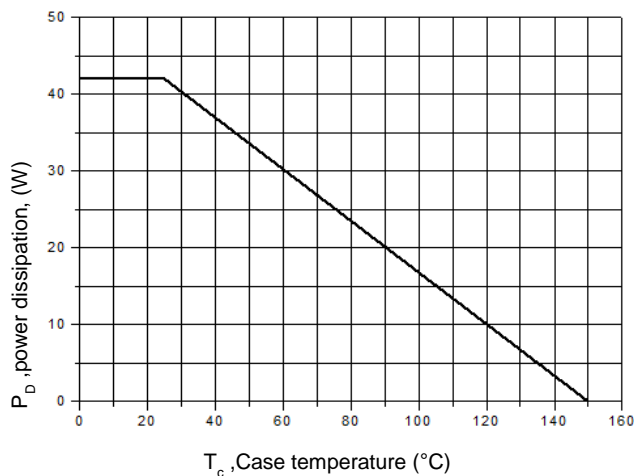

Figure 12. Power Dissipation vs. Temperature
TO-220/ TO-262/TO-263

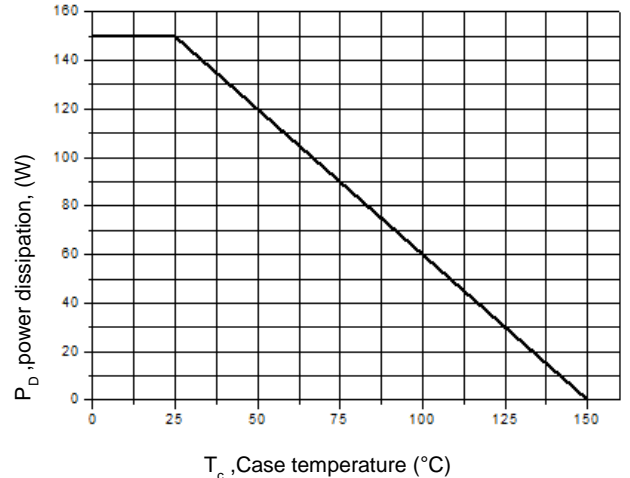

Figure 13. Continuous Drain Current vs. Temperature

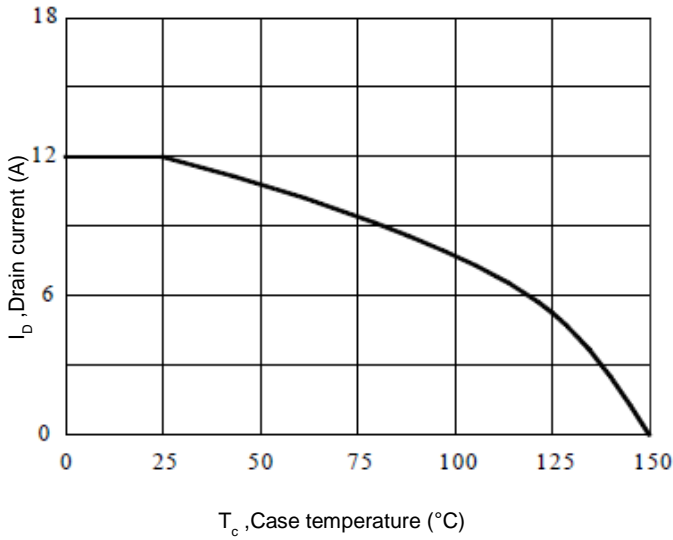

Figure 14. Body Diode Transfer Characteristics

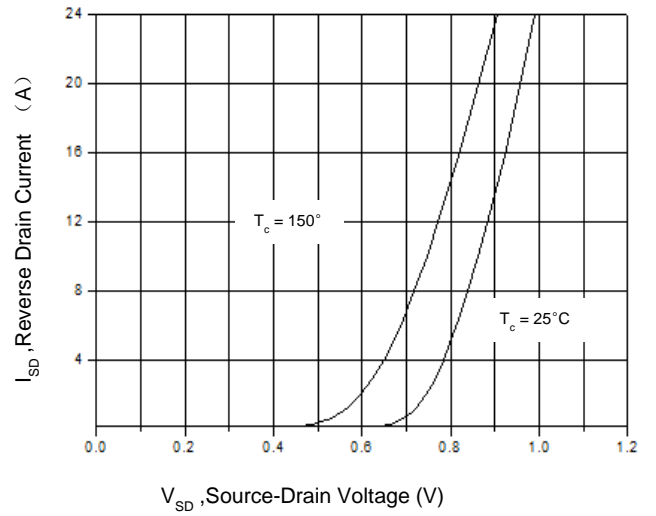

Figure 15 Transient Thermal Impedance, Junction to Case, TO-220F

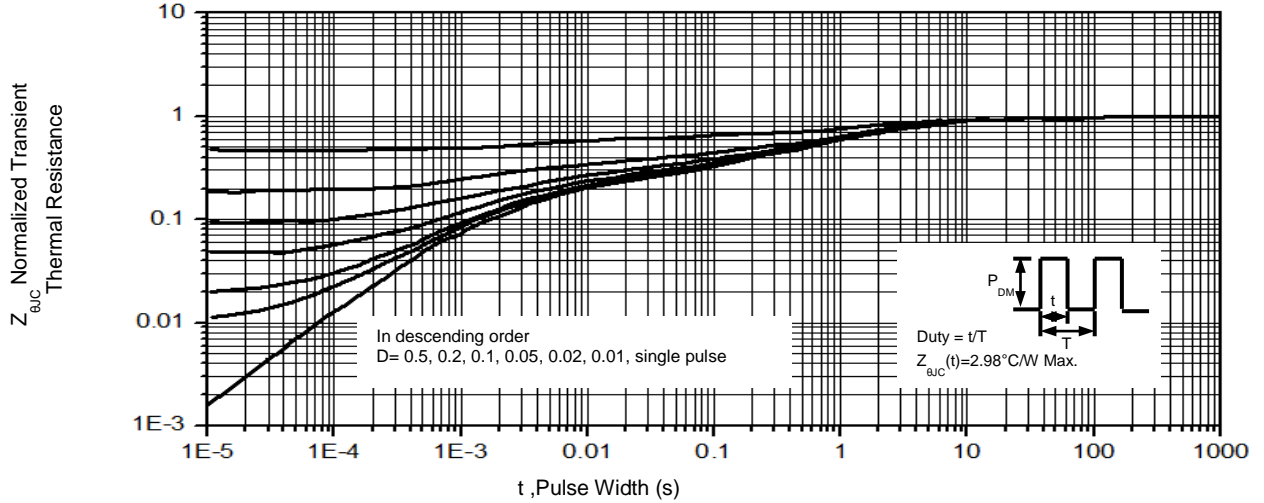
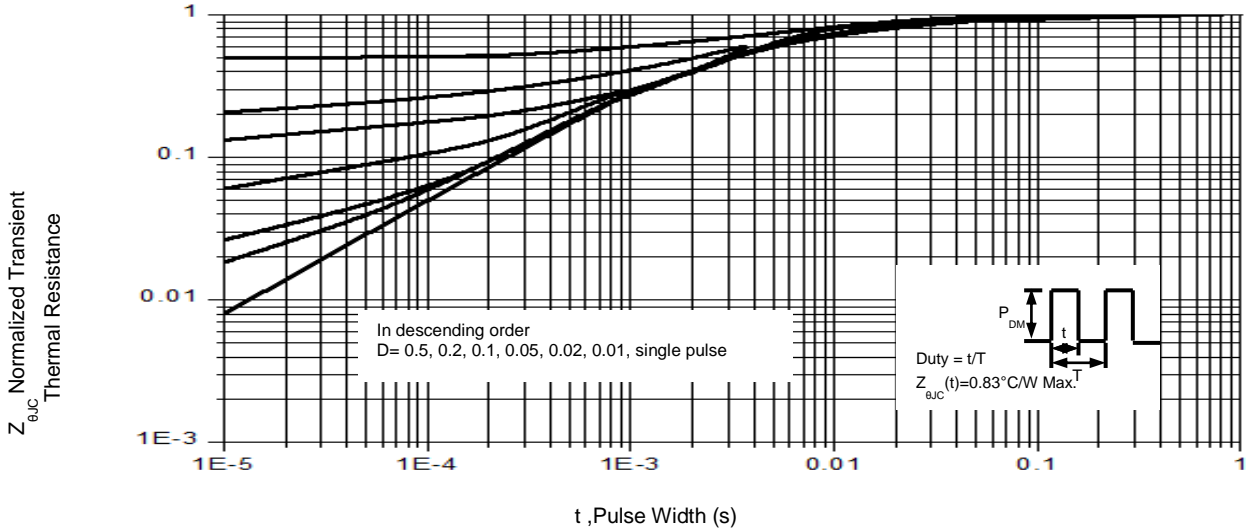
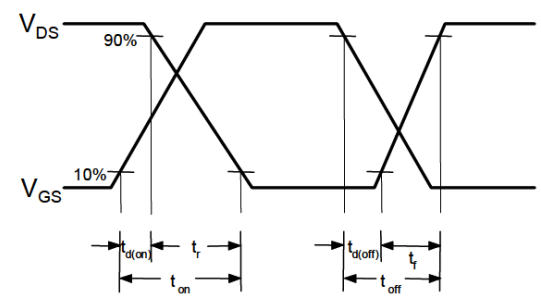
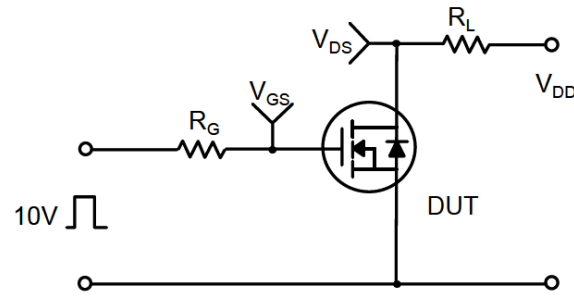
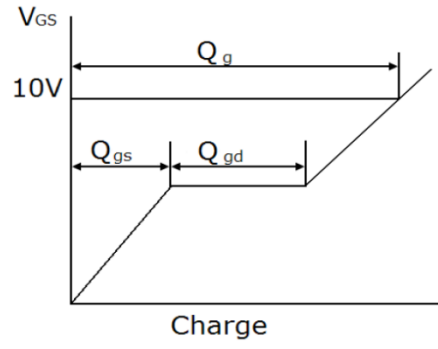
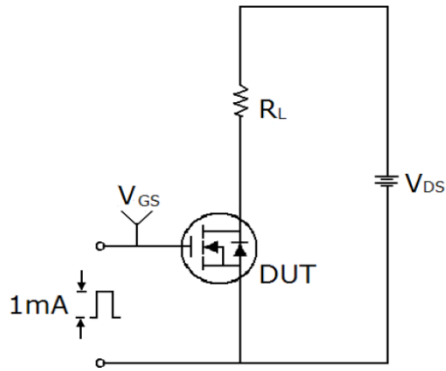

Figure 16. Transient Thermal Impedance, Junction to Case, TO-220/ TO-262/TO-263



Gate Charge Test Circuit & Waveform



Unclamped Inductive Switching Test Circuit & Waveforms

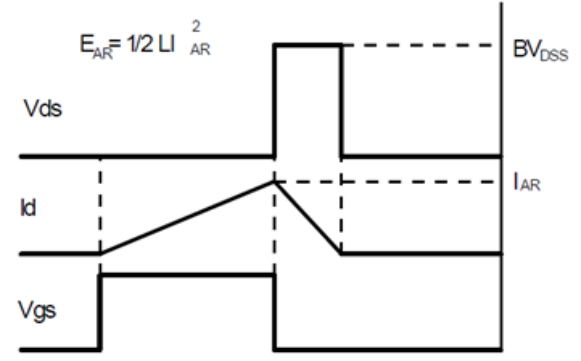
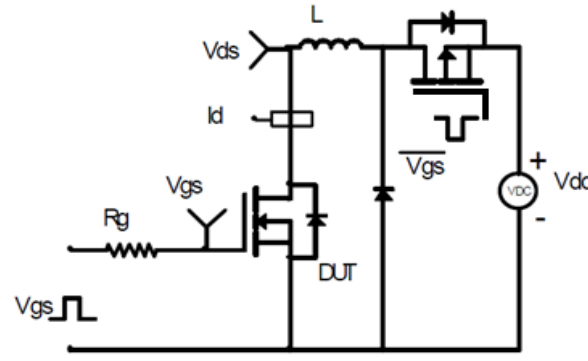

Mechanical Dimensions for TO-220

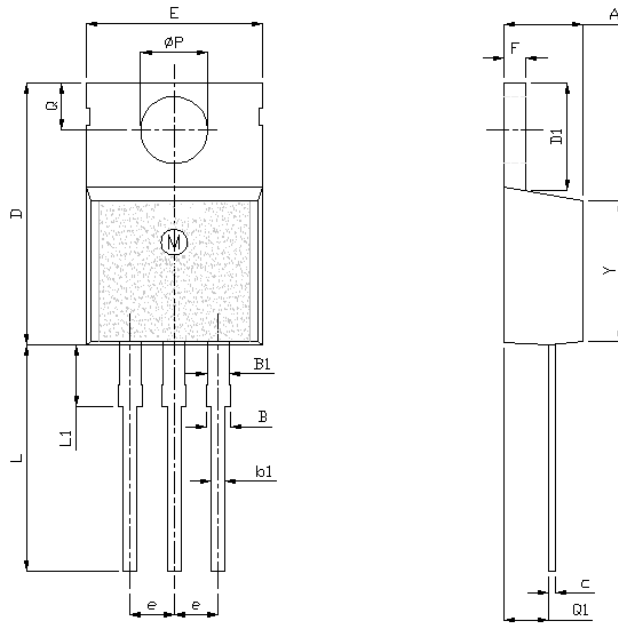

UNIT: mm

SYMBOL	MIN	NOM	MAX
A	4		4.8
B	1.2		1.4
B1	1		1.4
b1	0.75		0.95
c	0.4		0.55
D	15		16.5
D1	5.9		6.9
E	9.9		10.7
e	2.44	2.54	2.64
F	1.1		1.4
L	12.5		14.5
L1	3	3.5	4
ΦP	3.7	3.8	3.9
Q	2.5		3
Q1	2		2.9
Y	8.02	8.12	8.22

TO-220 Part Marking Information

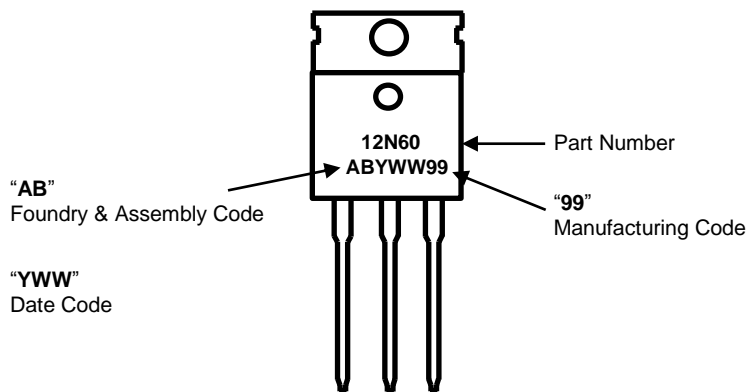

Mechanical Dimensions for TO-220F

UNIT: mm

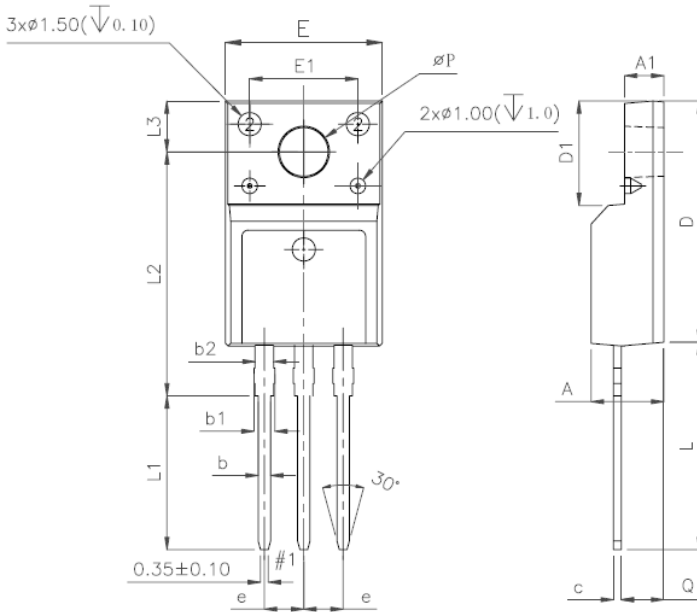

SYMBOL	MIN	NOM	MAX
A	4.5		4.9
A1	2.3		2.9
b	0.65		0.9
b1	1.1		1.7
b2	1.2		1.4
c	0.35		0.65
D	14.5		16.5
D1	6.1		6.9
E	9.6		10.3
E1	6.5	7	7.5
e	2.44	2.54	2.64
L	12.5		14.3
L1	9.45		10.05
L2	15		16
L3	3.2		4.4
φP	3		3.3
Q	2.5		2.9

TO-220F Part Marking Information

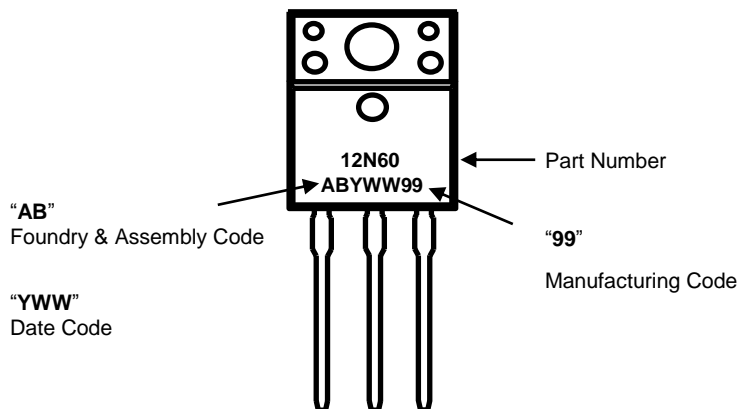

Mechanical Dimensions for TO-262

UNIT: mm

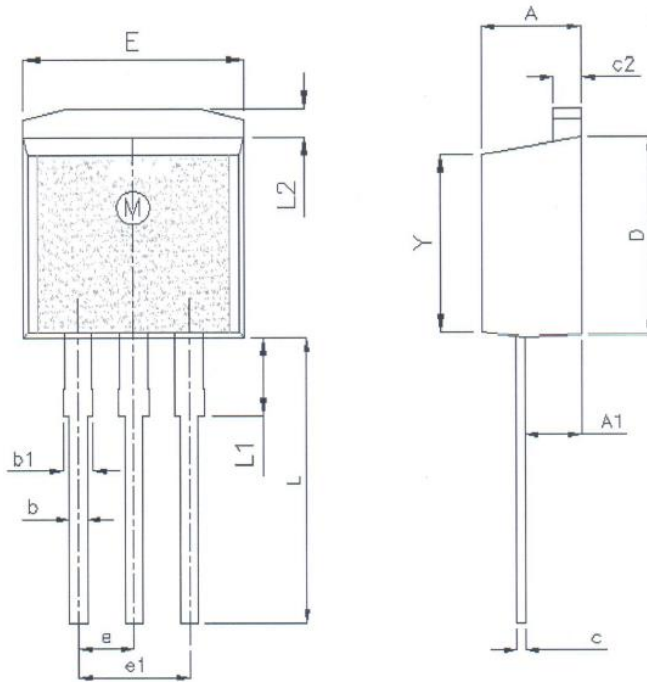

SYMBOL	MIN	NOM	MAX
A	4.42		4.72
A1	2.40		2.80
b	0.76		0.86
b1	1.22		1.40
c	0.33		0.43
c2	1.22		1.35
D	8.99		9.29
e	2.44	2.54	2.64
e1	4.98		5.18
E	9.95		10.25
L	12.50		13.60
L1	3.30	3.50	3.80
L2	1.22		1.40
Y	8.02	8.12	8.22

TO-262 Part Marking Information

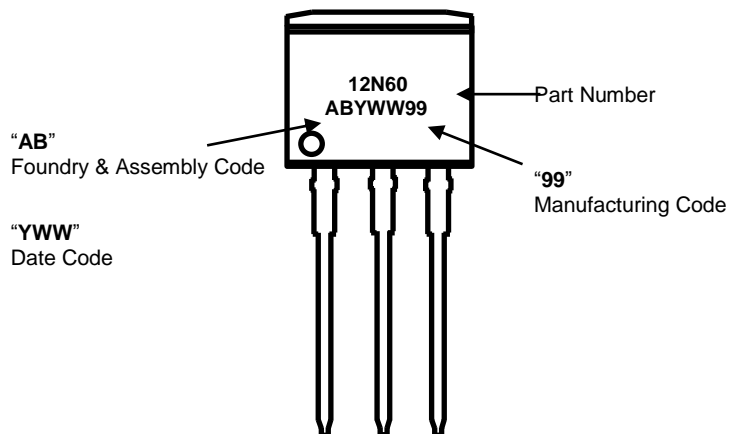

Mechanical Dimensions for TO-263

UNIT: mm

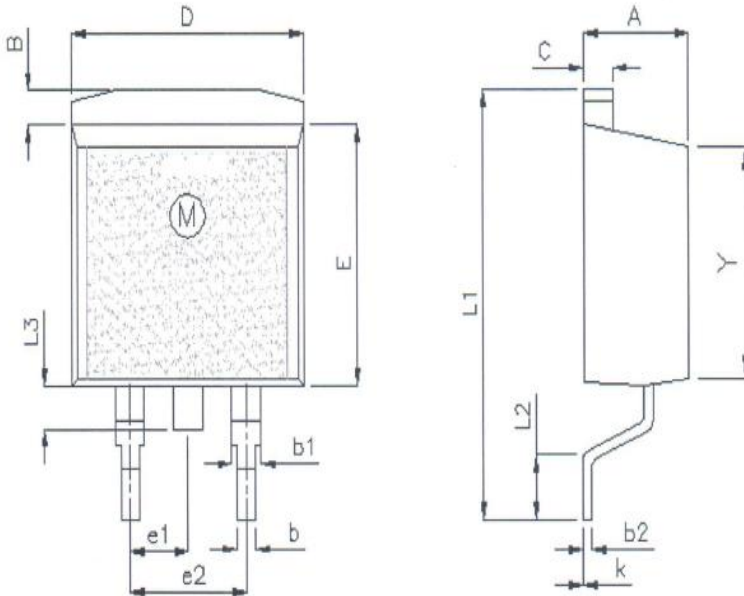

SYMBOL	MIN	NOM	MAX
A	4.42		4.72
B	1.22		1.4
b	0.76		0.86
b1	1.22		1.4
b2	0.33		0.43
C	1.22		1.35
D	9.95		10.25
E	8.99		9.29
e1	2.44	2.54	2.64
e2	4.98		5.18
L1	14.7	15.1	15.5
L2	2	2.3	2.6
L3	1.5		2
K	-0.1		0.1
Y	8.02	8.12	8.22

TO-263 Part Marking Information

