

Product Specification

LDY Type

GGA TL431LB

Features

- Equivalent Full Range Temperature Coefficient 50PPM/°C
- Temperature Compensated For Operation Over Full Rate Operating Temperature Range
- Adjustable Output Voltage
- Fast Turn-on Response
- Sink Current Capability 1mA to 100mA
- Low (0.27Ω Typ.) Dynamic Output Impedance
- Low Output Noise

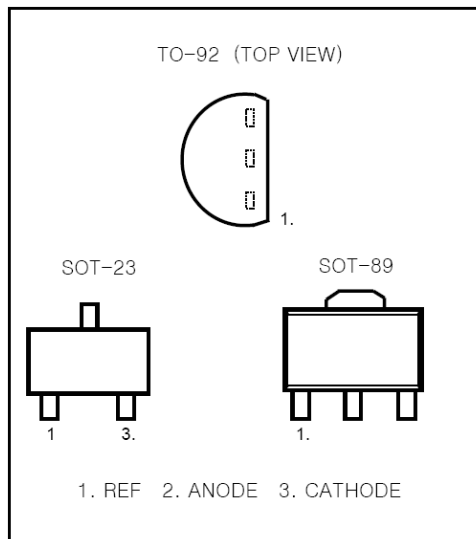

DESCRIPTION

The TL431 is three-terminal adjustable shunt regulator with specified thermal stability. The output voltage may be set to any value between VREF(Approx. 2.5V) and 36V with two external resistors. This device has a typical output impedance of 0.2Ω. Active output circuitry provides a very sharp turn-on characteristic, making this device excellent replacement for zener diodes in many application.

FUNCTION BLOCK DIAGRAM

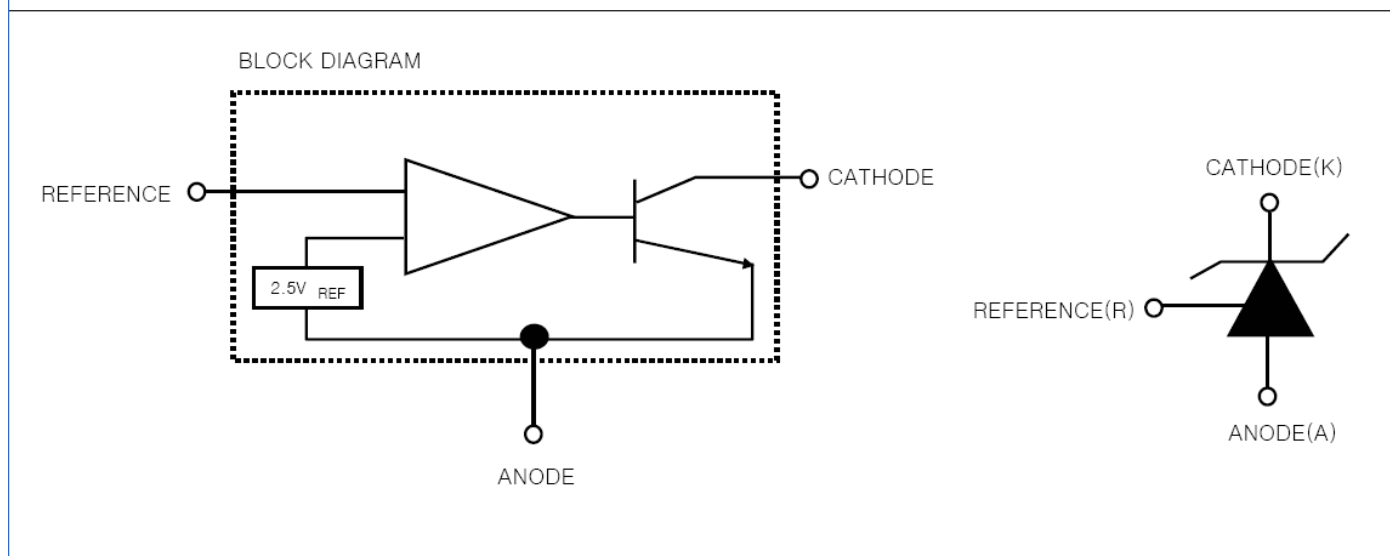

ABSOLUTE MAXIMUM RATINGS

(Full Operating Ambient Temperature Range Applies Unless Otherwise Noted)

CHARACTERISTIC	SYMBOL	RATING	UNIT
Cathode Voltage	V_{KA}	40	V
Continuous Cathode Current Range	I_{KA}	-100~+150	mA
Reference Input Current Range	I_{REF}	0.05~10	mA
Junction Temperature	T_J	150	°C
Operating Temperature	T_{OPR}	-20 ~ 85	°C
Storage Temperature	T_{STG}	-65 ~ 150	°C
Total Power Dissipation	P_D	700	mW

ELECTRICAL CHARACTERISTICS

($T_a = 25^\circ\text{C}$, $V_{KA} = V_{REF}$, $I_K = 10\text{mA}$ unless otherwise specified)

Characteristic	Symbol	Test Condition	Min	Typ	Max	Unit
Reference Input Voltage	V_{REF}	$V_{KA} = V_{REF}$, $I_K = 10\text{mA}$	2.483	2.495	2.507	V
Deviation of Reference Input Voltage Over Full Temperature Range	$V_{REF(dev)}$	$T_{min} \leq T_a \leq T_{max}$		3	17	mV
Ratio of Change in Reference Input Voltage to the Change in Cathode Voltage	$\Delta V_{REF}/\Delta V_{KA}$	$\Delta V_{KA} = 10\text{V} - V_{REF}$ $\Delta V_{KA} = 36\text{V} - 10\text{V}$	-0.4 -0.4	0.0 0.0	2.7 2.0	mV/V
Reference Input Current	I_{REF}	$R_1 = 10\text{K}\Omega$, $R_2 = \infty$		1.8	4	μA
Deviation of Reference Input Current Over Full Temperature Range	$I_{REF(dev)}$	$R_1 = 10\text{K}\Omega$, $R_2 = \infty$		0.4	1.2	μA
Minimum Cathode Current for Regulation	$I_{K(min)}$			0.25	0.5	mA
Off-State Cathode Current	$I_{K(off)}$	$V_{KA} = 40\text{V}$, $V_{REF} = 0$		0.17	0.9	μA
Dynamic Impedance	Z_{KA}	$I_K = 10\text{mA}$ to 100mA , $f \leq 1.0\text{KHz}$		0.27	0.5	Ω

Fig. 1 Test Circuit for $V_{KA} = V_{REF}$

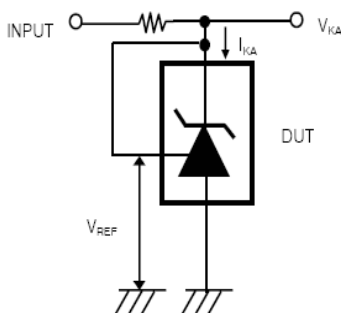

Fig. 2 Test Circuit for $V_{KA} \geq V_{REF}$

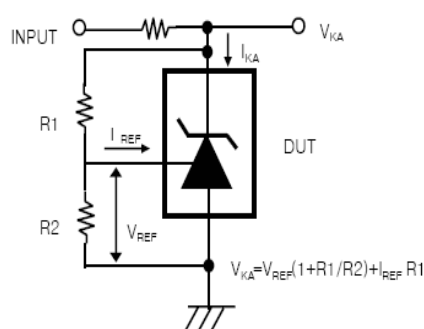
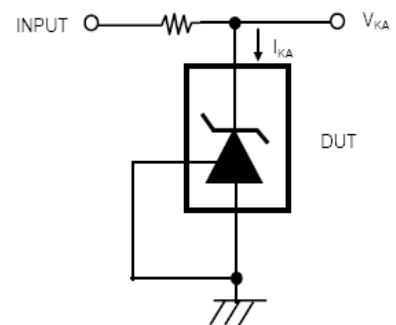
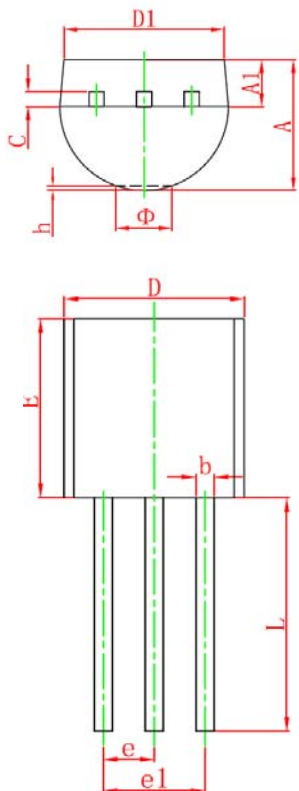

Fig. 3 Test Circuit for $I_{KA} (off)$



TO-92 PACKAGE OUTLINE DIMENSIONS



Symbol	Dimensions In Millimeters		Dimensions In Inches	
	Min	Max	Min	Max
A	3.300	3.700	0.130	0.146
A1	1.100	1.400	0.043	0.055
b	0.380	0.550	0.015	0.022
c	0.360	0.510	0.014	0.020
D	4.400	4.700	0.173	0.185
D1	3.430		0.135	
E	4.300	4.700	0.169	0.185
e	1.270 TYP		0.050 TYP	
e1	2.440	2.640	0.096	0.104
L	14.100	14.500	0.555	0.571
Φ		1.600		0.063
h	0.000	0.380	0.000	0.015

SOT-89-3L PACKAGE OUTLINE DIMENSIONS

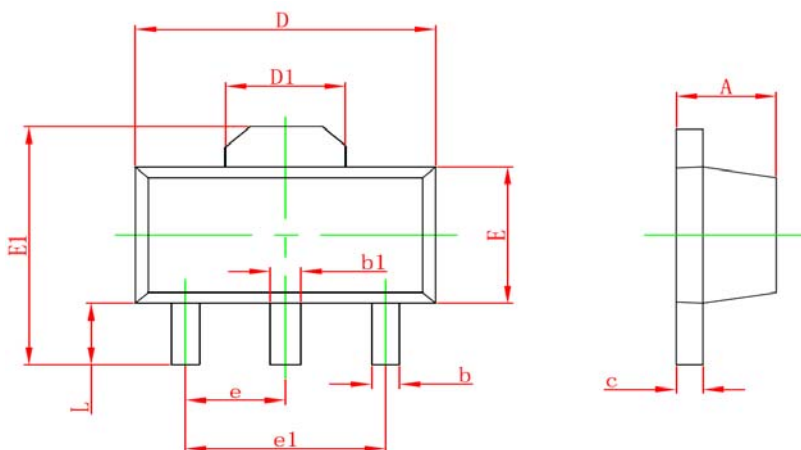

Symbol	Dimensions In Millimeters		Dimensions In Inches	
	Min	Max	Min	Max
A	1.400	1.600	0.055	0.063
b	0.320	0.520	0.013	0.197
b1	0.400	0.580	0.016	0.023
c	0.350	0.440	0.014	0.017
D	4.400	4.600	0.173	0.181
D1	1.550 REF		0.061 REF	
E	2.300	2.600	0.091	0.102
E1	3.940	4.250	0.155	0.167
e	1.500 TYP		0.060 TYP	
e1	3.000 TYP		0.118 TYP	
L	0.900	1.200	0.035	0.047

SOT-23-3L PACKAGE OUTLINE DIMENSIONS

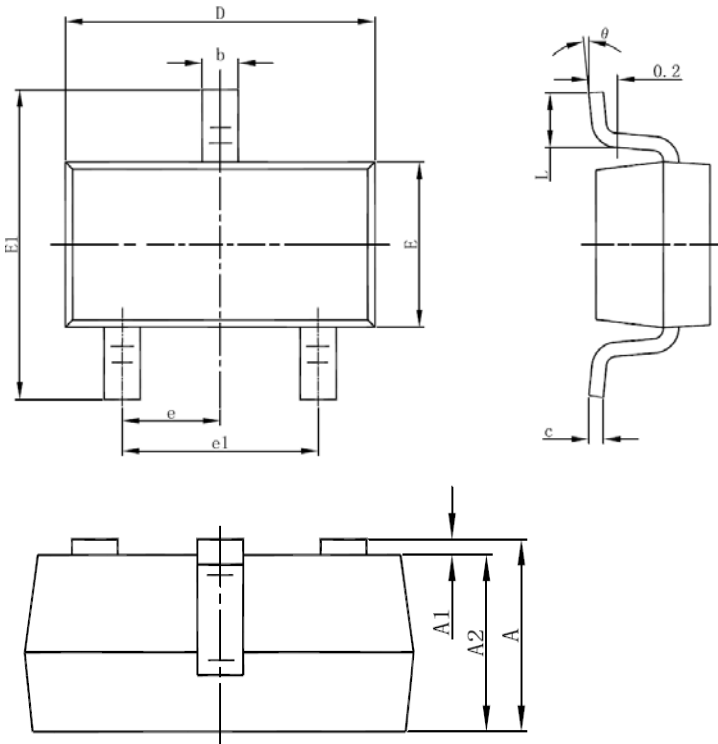

Symbol	Dimensions In Millimeters		Dimensions In Inches	
	Min	Max	Min	Max
A	1.050	1.250	0.041	0.049
A1	0.000	0.100	0.000	0.004
A2	1.050	1.150	0.041	0.045
b	0.300	0.500	0.012	0.020
c	0.100	0.200	0.004	0.008
D	2.820	3.020	0.111	0.119
E	1.500	1.700	0.059	0.067
E1	2.650	2.950	0.104	0.116
e	0.950(BSC)		0.037(BSC)	
e1	1.800	2.000	0.071	0.079
L	0.300	0.600	0.012	0.024
θ	0°	8°	0°	8°